

Vehicle Type / Type : DJ1

Manufacturer : Mazda Motor Europe GmbH

---

## TEST REPORT

according to ECE-Regulation

### Uniform provisions concerning the approval of devices for indirect vision and of motor vehicles with regard to the installation of these devices

ECE-R46 including Amendment 04, Suppl. 1

---

Approval Status

Test Report : ---

---

#### Structure of the Test Report

Item No.

0. General information
  1. Tested vehicle(s) / object(s)
  2. Test record
  3. List of appendices
  4. Statement of conformity
  5. List of modifications
- 

The Test Report shall be reproduced and published in full by the client only. It shall however be reproduced partially with the written permission of the Testing Service only.

Vehicle Type / Type : DJ1

Manufacturer : Mazda Motor Europe GmbH

## 0. General information

- 0.1. Make (Trade name of the manufacturer) : Mazda
- 0.2. Type : DJ1
- 0.3. Category of vehicle : M1
- 0.4. Name and address of the manufacturer : Mazda Motor Europe GmbH  
Hitdorfer Str. 73  
51371 Leverkusen  
Germany
- 0.4.1. Name and address of the manufacturer's representative : N/A
- 0.5. Information document No. : ---  
- Date of issue : ---  
- Date of last change : ---

## 1. Tested vehicle(s) / object(s)

- 1.1. Description
- Vehicle(s) : Representative vehicles
- Commercial name(s) : Mazda2 and CX3
- Additional parts (part no.) : Interior mirror; Class I; Gentex, E11 02 6133 (0000 8C P14 or 0000 89 P25)
- 1.2. Worst case selection : The determination of "worst case scenario" was done according to internal procedures of the Technical Service (QMA 1.301.005, section 6.2.2.2.).
- 1.3. Remark(s) : The vehicle type(s) was/were newly inspected with regard to the additional parts listed above and described in the annex.

Vehicle Type / Type : DJ1

Manufacturer : Mazda Motor Europe GmbH

## 2. Test record

- 2.1. Test facilities : The test facilities/measurement equipment used was/were in compliance with the test requirements.
- 2.1.1. Specifications for the test site : N/A
- 2.2. Test results
- The vehicle type has been inspected with regard to the effect of the additional parts listed in 1. in comparison to the affected system approval.  
The base vehicle type is approved by E1 46R-041402 Ext.04.  
After inspection the vehicle types with these additional parts can be considered to comply with all requirements of the Regulation. With regard to the Regulations ECE-R21 and ECE-R125 the interior mirror does not apply to these regulations.
- Remark(s) concerning extension : N/A
- 2.2.1. Indirect Vision (ECE-R46)
- 2.2.1.1. General specifications : The devices for indirect vision mounted on the vehicle are approved under the regulation. The field of vision is not changed by vibration or vehicle movement.
- 2.2.1.2. Mirrors
- Number : The number of mirrors is unchanged in comparison to the base vehicle.
- Position : The interior mirror is mounted to the same position of the interior mirror of the base vehicle.
- Adjustment : Requirements fulfilled, mirrors are adjustable from driver position.
- Fields of vision
- Interior rear-view mirror (Class I) : Field of vision fulfilled.
- All other mirrors : See base vehicle approval.
- Obstructions : Fulfilled (obstructions by interior components <15%)

Vehicle Type / Type : DJ1

Manufacturer : Mazda Motor Europe GmbH

---

2.3. Additional information

Test site : Mazda Motor Europe, Oberursel  
TÜV Rheinland Kraftfahrt GmbH, Technology Center  
Traffic Safety, Köln

Test date : 2015-12-09

2.4. Remark(s) : The results of the test refer exclusively to the object(s)  
mentioned under point 1. of this report.

3. List of appendices

1 : Photo/Drawings of additional parts

4. Statement of conformity

The at section 0.5. mentioned information document and the type described in that comply with the requirements mentioned on page 1.

With regard to the required level of performance to be achieved, the tested samples were representative for the type to be approved (see section 1.2).

The tests were carried out in accordance with the relevant requirements of EN ISO/IEC 17020:2012.

Köln, 2015-12-14



Dipl.-Ing. Christian von Stosch  
Expert Technical Service

Vehicle Type / Type : DJ1

Manufacturer : Mazda Motor Europe GmbH

---

**5. List of modifications**

Correction of : --  
Modification of : --  
Addition of : --  
Deletion of : --

Vehicle Type / Type : DJ1

Manufacturer : Mazda Motor Europe GmbH

Appendix 1

Photo/Drawings of additional parts

RESTRICTED

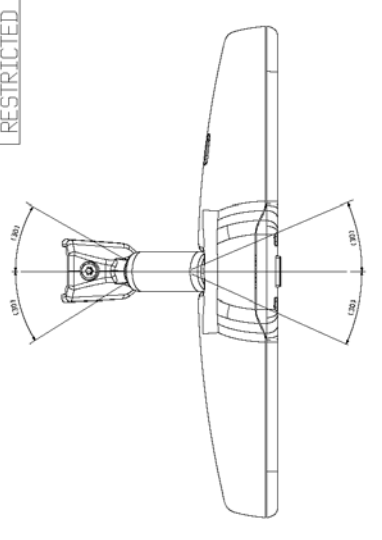

NOTE: 1. THIS PRODUCT IS TO CONFORM TO PHASE 111 AND 302  
 2. PAINT OF FINISH SHALL ALLOWED TO BE SPECIFIED DUE TO PRODUCTION VARIATION.  
 3. THIS PRODUCT IS TO CONFORM TO THE FOLLOWING INTD PERFORMANCE SPECIFICATIONS:

NO.	ITEM	SPECIFICATION
1	OPERATING CURRENT	9 - 15 VDC
2	OPERATING CURRENT AT 1000 RPM	1500 mA MAX.
3	CURRENT IN OFF POSITION	100 mA

NOTE: 4. THIS IS A NEW PART TO BE USED.  
 5. PAINT APPROVAL REQUIRED PRIOR TO START OF PRODUCTION.  
 6. ANY CHANGE TO PART OR DRAWING MUST BE APPROVED BY THE ORIGINAL DESIGNER.  
 7. PROVISIONS NOT CONFORM TO GUIDELINE ESTABLISHED BY THE APPLICABLE STANDARD SHALL BE INDICATED BY DIMENSION LINE.  
 8. DIMENSIONS ARE IN MILLIMETERS (MM).

REV.	DATE	DESCRIPTION	BY	CHKD.
1	03.23.15	ISSUED FOR DRAWING		
2	03.23.15	REVISED		

DATE: 03.23.15  
 TIME: 10:00  
 DRAWN BY: JUDAWK  
 CHECKED BY: JUDAWK  
 PART NO.: 88.23.15  
 SCALE: 2 OF 3  
 PART NAME: SEE CHPT  
 TYPE: EC MARKER WITH ADDRESS  
 I.D.C. NO.: 0008 8C P14

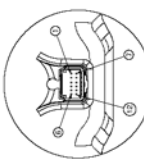

Auxiliary View B  
Scale: 1:1

